

Advanced Automatic Bidirectional Optical Line Protection & Reversion Switch



The Agiltron Bidirectional Optical Line Protection (BOLP) System is a carrier-grade, protocol-transparent switching solution designed to provide automatic restoration and non-latching automatic reversion for high-vulnerability single-fiber DWDM networks operating at data rates up to 200 Gbps. The system continuously monitors the optical continuity of the primary link using an out-of-band AUX-band laser pilot signal (typically employing CWDM wavelengths such as 1490nm + 1510nm) transmitted in the reverse direction of traffic at each node. Upon a physical fiber fault or cut, the received AUX-band optical power drops below a user-defined threshold, prompting the internal high-speed optical switches and circulators to automatically reroute the bidirectional DWDM traffic onto a geographically diverse backup fiber path in under 10 ms (with high-speed variants supporting 100 μ s or 10 μ s switching). Following a protection event, the centralized head-end hardware continues to actively probe and monitor the primary fiber link; once physical continuity is fully restored and a stable AUX laser signal level is verified above the threshold, the system automatically triggers a seamless reversion back to the primary path. This reversion logic features integrated transient stability metrics, rendering it completely immune to false switching cycles caused by premature Fresnel reflections during fiber splicing or connector reconnection. To maximize deployment efficiency and keep the Outside Plant (OSP) 100% passive, the BOLP system interfaces directly with uniquely engineered passive DWDM filters optimized for distinct network architectures. In a Cascaded (Daisy-Chained) Topology, passive OSP Optical Add-Drop Multiplexers (OADMs) are linked via their Expansion (EXP) ports over a single fiber, where the EXP port of the final OADM in the linear chain—ordinarily left unpopulated—is routed back to the central hub via a diverse fiber path to form a closed physical ring. Because Agiltron 1-fiber (1F) OADMs are inherently bidirectional and simultaneously broadcast add/drop channels to both their IN and EXP ports, the head-end hub can actively monitor primary link health even while active traffic traverses the backup path, triggering an automatic reversion the moment the primary fiber break is spliced and the AUX signal stabilizes. Alternatively, in a Hub & Spoke (H&S) Topology, where the fiber spectrum is coarsely partitioned at a centralized field location using a passive Band Splitter/Coupler (BSC) to feed localized sub-bands to downstream destinations, the linear distribution spurs maximize the optical budget but do not natively accommodate protection loops. Consequently, the BOLP system consolidates protection on the main head-end trunk line between the central hub and the BSC cabinet, utilizing dual independent protection switching modules to monitor aggregated optical power and the AUX pilot signal. If the main trunk line is severed, traffic is instantaneously forced over a secondary backup trunk fiber, and the moment primary trunk continuity is restored, the hub commands an automatic reversion back to the optimized primary link—ensuring the entire downstream spoke ecosystem transitions seamlessly back to the high-budget path without requiring field component intervention. Engineered for maximum uptime, the BOLP chassis features full hardware redundancy, utilizing dual hot-swappable DC power supplies (operating from -42 VDC to -70 VDC) and dual independent Ethernet communication controllers that feature automatic failover and proactive SNMP v3 alarm reporting, while each individual plug-in module provides a front-panel physical manual override push-button with a dedicated status LED to enable immediate bypass routing to a third port for local circuit maintenance and loopback testing.



Rev 05/27/26

[P +1 781-935-1200](tel:+17819351200)

[E sales@agiltron.com](mailto:sales@agiltron.com)

[W www.agiltron.com](http://www.agiltron.com)

Advanced Automatic Bidirectional Optical Line Protection & Reversion Switch

Features

- Bidirectional protection
- Reduce interruption time
- Increase reliability
- Improve service quality
- Fault tolerance
- Automatic switching
- DWDM

Applications

- Fiber Line Protection
- Ring Networks

Specifications [1]

Parameters	Min	Typical	Max	Unit
Operating Wavelength	1260-1650			nm
Insertion Loss [1], [2]		1.5	2	dB
Monitoring Power Range		-50	23	dBm
Return Loss		45		dB
Cross Talk On/Off Ratio		55		dB
PDL			0.05	dB
Optical Switching Time [4]	0.1	10	30	ms
Repeatability			± 0.05	dB
Noise Figure			30	dB
Signal Detection Range	-40		30	dBm
Durability [5]	10 ⁸		10 ¹³	Cycle
Operating Temperature	-5		60	°C
Storage Temperature	-40		85	°C
Monitor Port/Interface [6]	RJ45, Console, SFP, CLI, SSH, Telnet, SNMP			
Power Supply	DC: -48~70V; AC: 110~220V (50/60 Hz), 50W, Dual and Hot Swappable			
Alarms	Signal Degradation, Switching Event, Fan Failure, CPU at high work load			
Fiber Type	SMF-28 or equivalent			
Chassis Type	19" Rack, 1U Supports 4 Channels with Dimension 44.5x482.6x300mm			
Internal Cooling Fan	Included			
Relative Humidity	5-95%			

Notes:

- [1]. Excluding connectors
- [2]. Multimode IL measure @ Light Source CPR<14 dB
- [3]. Dual band, and Dual 1x2, Full 2x2, Dual Full 2x2
- [4]. Optical switch speed, there are electrical signal delay in the system
- [5]. Higher reliability switches are available
- [6]. A basic SNMP interface is included for customers to write their application-specific code. We provide code writing with NRE

Function Diagram

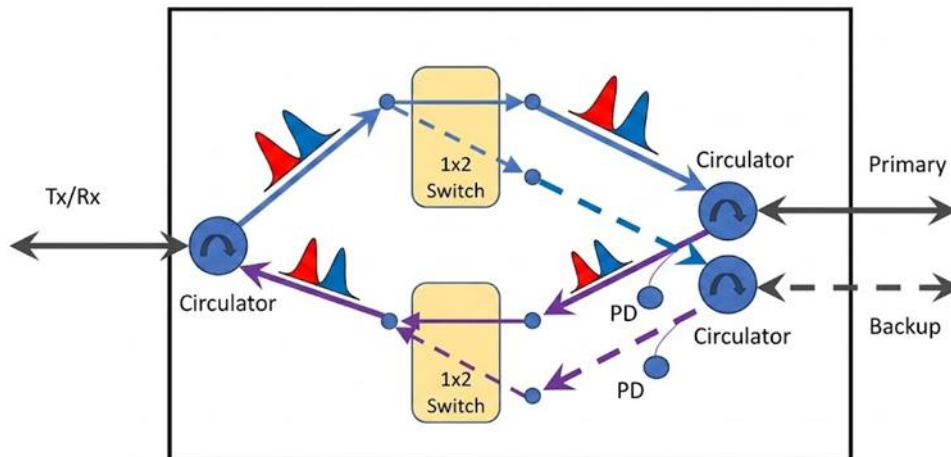

Advanced Automatic Bidirectional Optical Line Protection & Reversion Switch

Mechanical Dimensions (mm)

1RU 19" mount rack. The input and output connectors and the control interface are on the front panel, while and power inputs are on the rear panel.

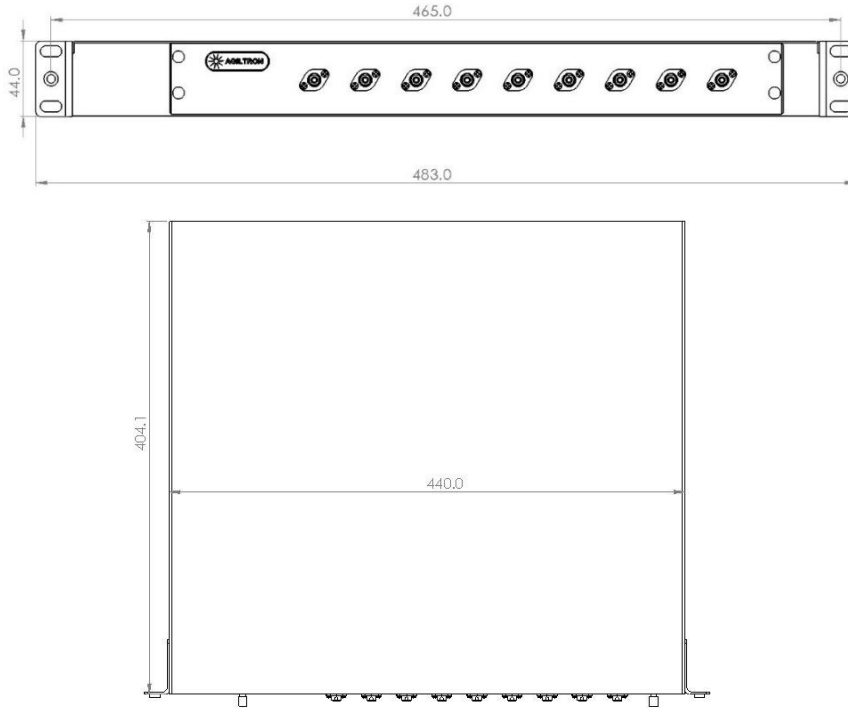

*Product dimensions may change without notice. This is sometimes required for non-standard specifications.

Ordering Information (Part Number)

Prefix	Type	Channel	Wavelength	Package ^[1]	Fiber Type	Switch Type	Power Supply	Connector ^[2]
BOLP-	1:1 = 1	1 = 01 2 = 02 ... 99 = 99 Special = 00	1260-1650nm = 1 Special = 0	1RU = 1 2RU = 2 3RU = 3 4RU = 4 Special = 0	SMF28e = 1 MM50/125 = 5 MM62.5/125 = 6 Special = 0	10 ms = 1 100 μs = 2 10 μs = 3	-48~70VDC = 2 110~220V AC = 3 Special = 0	FC/APC = 1 FC/PC = 2 SC/PC = 4 SC/APC = 5 ST/PC = 6 LC/PC = 7 Duplex LC/PC = 8 LC/UPC = U MPO = Y Special = 0

[1]. Rack Mount Depth ~ 430mm.

[2]. The connector cannot be installed directly onto bare fiber, as it is prone to damage during shipping. However, the connector can be assembled on bare fiber if a 3 cm protective loose tube is added for reinforcement. The customer can remove this protective tube after testing. The optical power handling of a standard connector is less than 0.5 W for SM28 fiber and decreases further with smaller core fibers.

Advanced Automatic Bidirectional Optical Line Protection & Reversion Switch

Ring Application Diagram

● No Ring Failure

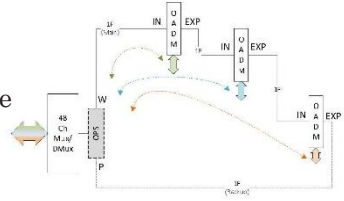

● Ring Failure

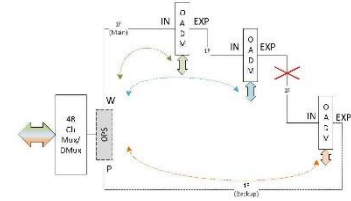

Agiltron Optical Line Protection Module (OLPM) in Hub & Spoke (H&S) Topology

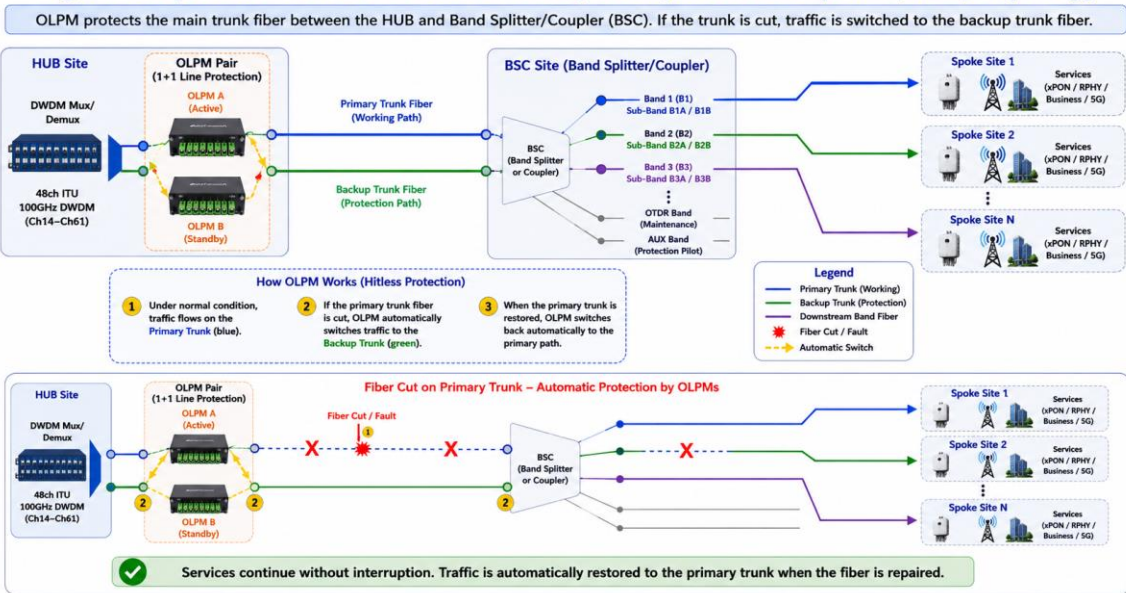

Agiltron Optical Line Protection Module (OLPM) in Cascaded Topologies

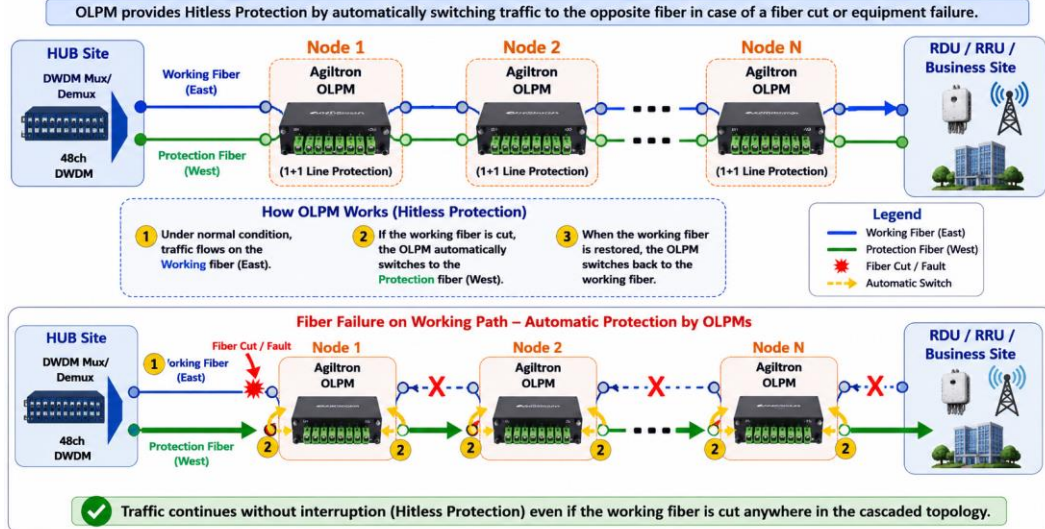

Advanced Automatic Bidirectional Optical Line Protection & Reversion Switch

An Example of TRAPS

SNMP TRAP	Description	Object Identifier/SNMP trap receiver display
OLP channel change	In the last 1.3.9 of the OID, 1 indicates the slot, 3 indicates the OLP board, 9 indicates the working channel, value=100 indicates that the current channel is the main channel, and value=200 indicates that the current channel is the backup channel	1.3.6.1.2.1.1.3.0 1.3.6.1.6.3.1.1.4.1.0 1.3.6.1.4.1.40989.10.16.1.3.9
OLP R1 alarm state	In the last 1.3.26 of the OID, 1 indicates the slot, 3 indicates the OLP board, 26 indicates the R1 alarm status, value=1 indicates that the current R1 power has changed from being less than the switching threshold state to being greater than the switching threshold state, and value=0 indicates the current R1 power From the state greater than the switching threshold to the state less than the switching threshold	1.3.6.1.2.1.1.3.0 1.3.6.1.6.3.1.1.4.1.0 1.3.6.1.4.1.40989.10.16.1.3.26
OLP R2 alarm state	In the last 1.3.27 of the OID, 1 indicates the slot, 3 indicates the OLP board, 27 indicates the R2 alarm status, value=1 indicates that the current power of R2 has changed from being less than the switching threshold state to being greater than the switching threshold state, and value=0 indicates the current power of R2 From the state greater than the switching threshold to the state less than the switching threshold	1.3.6.1.2.1.1.3.0 1.3.6.1.6.3.1.1.4.1.0 1.3.6.1.4.1.40989.10.16.1.3.27
OLP TX alarm state	In the last 1.3.28 of the OID, 1 indicates the slot, 3 indicates the OLP board, 28 indicates the TX alarm status, value=1 indicates that the current power of the TX has changed from being less than the switching threshold state to being greater than the switching threshold state, and value=0 indicates the current power of the TX From the state greater than the switching threshold to the state less than the switching threshold	1.3.6.1.2.1.1.3.0 1.3.6.1.6.3.1.1.4.1.0 1.3.6.1.4.1.40989.10.16.1.3.28

Advanced Automatic Bidirectional Optical Line Protection & Reversion Switch

Ethernet Remote Control with Python

Several options: Telnet, HTTP/JSON API, or VISA Raw Socket mode (SCPI over TCP/IP)

```
#####  
Telnet:  
  
import telnetlib  
  
HOST = "192.168.0.1"  
PORT = 23  
  
#####  
username = "admin"  
password="admin"  
#####  
tn=telnetlib.Telnet (HOST,PORT)  
  
reply=tn.read_until(b"username:",timeout=10)  
print(reply.decode("ascii"))#debug  
tn.write(username.encode("ascii")+b"\r\n")  
  
reply=tn.read_until(b"password:",timeout=10)  
print(reply.decode("ascii"))#debug  
tn.write(password.encode("ascii")+b"\r\n")  
  
reply=tn.read_until(b"telnet>",timeout=10)  
print(reply.decode("ascii"))#debug  
  
tn.write(b"setswitch 31 32 0 0\r\n")  
reply=tn.read_until(b"telnet>",timeout=10)  
print(reply.decode("ascii"))#debug  
  
tn.write(b"runswitch\r\n")  
reply=tn.read_until(b"telnet>",timeout=10)  
print(reply.decode("ascii"))#debug  
  
tn.write(b"quit\r\n")  
  
#####
```

Advanced Automatic Bidirectional Optical Line Protection & Reversion Switch

Ethernet Remote Control with Python (ending)

Several options: Telnet, HTTP/JSON API, or VISA Raw Socket mode (SCPI over TCP/IP)

```
#####
API:
import requests

BASE_URL = "
TOKEN = "TOKEN"
def api_post(path, payload):
    r = requests.post(
        BASE_URL + path,
        json=payload,
        headers={"X-Auth-Token": TOKEN},
        timeout=3,
    )
    r.raise_for_status()
    return r.json()

def api_get(path):
    r = requests.get(
        BASE_URL + path,
        headers={"X-Auth-Token": TOKEN},
        timeout=3,
    )
    r.raise_for_status()
    return r.json()

# Set port 3
print(api_post("/api/set_permanent_port", {"port": 3}))
# Read status
print(api_get("/api/status"))

#####
pyVISA:
import pyvisa

HOST = "192.168.0.1"
TOKEN = "TOKEN"

rm = pyvisa.ResourceManager()

inst = rm.open_resource(f"TCPIP0::{HOST}::5025::SOCKET")
inst.read_termination = "\n"
inst.write_termination = "\n"
inst.timeout = 2000 # ms

print("IDN:", inst.query("*IDN?").strip())

# Set port
inst.write("SWITCH:PERMANENTPORT 3")
print("PORT?:", inst.query("SWITCH:PERMANENTPORT?").strip())

# Status
print("STATUS:", inst.query("SWITCH:STATUS?").strip())

#####
```

Advanced Automatic Bidirectional Optical Line Protection & Reversion Switch

Questions and Answers

Q: If the device were to fail, would the switch continue to pass the fiber light through the switch as configured before failure? When power is restored, does the IN/OUT configuration before failure remain in place?

A: This depends, if one mirror fails, it only affects the light go through that mirror. Yes, when power back up it will go to the previous points

Q: When power is restored, does the IN/OUT configuration before failure remain in place?

A: Yes, when power back up it will go to the previous flightpath

Q: If power to the device were shutoff, would the device continue to pass the fiber light as configured before failure?

A: This function is call latching. We uniquely offer MEMS latching switch but cost more.

Q: With the Ethernet Control Option, does the switch support SNMPv3

A: Yes. This internet standard protocol allows user to write their own control code

Q: With the Ethernet Control Option, what type of encryption does the SNMPv3 use?

A: MD5/DES

Q: With the Ethernet Control Option, could this switch be controlled by multiple users at different locations and all users will also see the configuration updates?

A: Yes

Q: With the Ethernet Control Option, does the user need to install any software on their computer other than a web browser?

A: No

Q: What OLP configuration affects the response characters?

A: The switch choice affects the most, however, the switch with fast rise/fall is more expensive. 1+1 only involves one switching, thus the performance is better than 1:1, but at the expense of half the signal lost.

Q: What OLP configuration affects the detection accuracy for low signal traffic?

A: OLP uses tap monitors to automatically detect fault. The tap ratio can be increased to provide more accurate detection for low signal levels, but this is at the expense of more signal losses.

Laser Safety

This product meets the appropriate standard in Title 21 of the Code of Federal Regulations (CFR). FDA/CDRH Class 1M laser product. This device has been classified with the FDA/CDRH under accession number 0220191. All versions of this laser are Class 1M laser products, tested according to IEC 60825-1:2007 / EN 60825-1:2007. An additional warning for Class 1M laser products. For diverging beams, this warning shall state that viewing the laser output with certain optical instruments (for example eye loupes, magnifiers, and microscopes) within a distance of 100 mm may pose an eye hazard. For collimated beams, this warning shall state that viewing the laser output with certain instruments designed for use at a distance (for example telescopes and binoculars) may pose an eye hazard.

Wavelength = 1.3/1.5 μ m.

Maximum power = 30 mW.



*Caution - Use of controls or adjustments or performance of procedures other than those specified herein may result in hazardous radiation exposure.

*IEC is a registered trademark of the International Electrotechnical Commission.